

Plastic-Framed High-Efficiency Gas Adsorbers

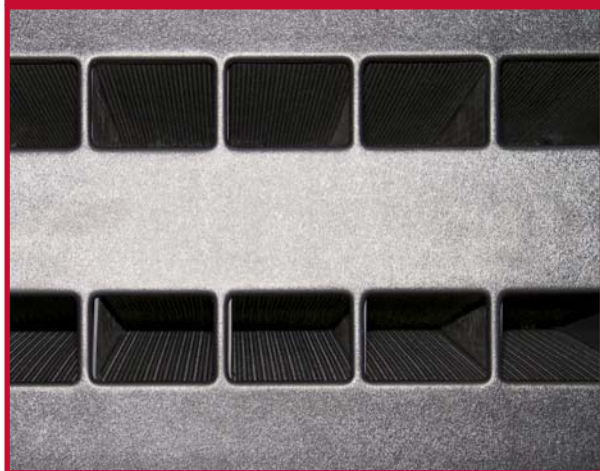

Containment of gaseous contaminants protecting people and the environment



V-bed air channels direct air through multiple beds of adsorbent. Modular frame construction ensures a rigid and durable enclosure.



Camfil Farr HEGA (high-efficiency gas adsorbers) will remove gaseous contaminants from air handling containment systems protecting the environment. For the safety of workers during HEGA change, service may be optionally accomplished through a bag-in/bag-out procedure. The Camfil Farr HEGA:

- Is manufactured of high-impact plastic, engineered to ensure enclosure rigidity and adsorbent retention
- Includes unique v-bed style air channels to reduce resistance to airflow
- Is corrosion-resistant
- May be incinerated
- Is easy to handle and less likely to damage containment bags during changeout
- Is available in a fluid-seal or gasket-seal design
- Is available with adsorbent bed depths of 1" or 2"
- May be filled with a variety of adsorbents to address gaseous contaminants specific to:
 - Radiological laboratories
 - Chemical and biological research facilities
 - Chemical warfare agent applications
 - Medical facilities
- Is less costly than alternative metal frame HEGAs
- Is manufactured under a quality Assurance Procedure that meets ASME NQA-1, Quality Assurance Program Requirements for Nuclear Facilities (all Camfil Farr facilities are also ISO 9001:2001)
- Is available constructed of optional stainless steel (contact factory).

Camfil Farr	Product bulletin
HEGA	3431 - 1207
Camfil Farr—clean air solutions	

Typical Applications	
Biotechnology Laboratories	Medical Facilities
Cancer Research Facilities	Military Facilities
Chemical Munitions Facilities	Nuclear Processing Facilities including utility power plants and research facilities
Chemical Manufacturing/Processing	Pharmaceutical Facilities
Department of Energy Facilities	University Laboratories
Industrial & Chemical Manufacturing Facilities	Veterinary & Animal Research Facilities

HEGAs are used in applications to ensure containment of hazardous gaseous contaminants. Normally installed in a system that also includes prefiltration and HEPA filtration, the HEGAs are changed using a bag-in/bag-out procedure.

Important factors in HEGA filter selection include the type (s) of contaminant (s), the velocity of the air in relation to the bed depth of the adsorbent (residence time), the capacity of the adsorber, and of course consideration of the disposal implications of the contaminated filters. On-site conditions such as temperature, humidity and ancillary gas levels also need to be considered.

With the most extensive carbon testing facility in the world, nuclear adsorber application history dating to the 1950s, and a staff of dedicated sorbent technology experts, Camfil Farr can provide the engineering assistance to ensure the safety of your facility and the employees that service the equipment.

When installed in Camfil Farr Safety & Protection containment housings a high level of worker and application protection is obtained. Camfil Farr HEGA filters are also available for containment housings constructed by other manufacturers.

The following chart provides some initial guidelines for your preliminary design, but we recommend consultation with our sorbent product engineering department before finalizing any HEGA application. Additionally HEGAs are usually part of a train of components that may include fail-safe dampers, prefiltration of particulates (protection of adsorbent pores) and HEPA filtration for sub-micron contaminant capture.

Consult factory, or your authorized representative for information on all containment train components.

MODEL NUMBER DATA

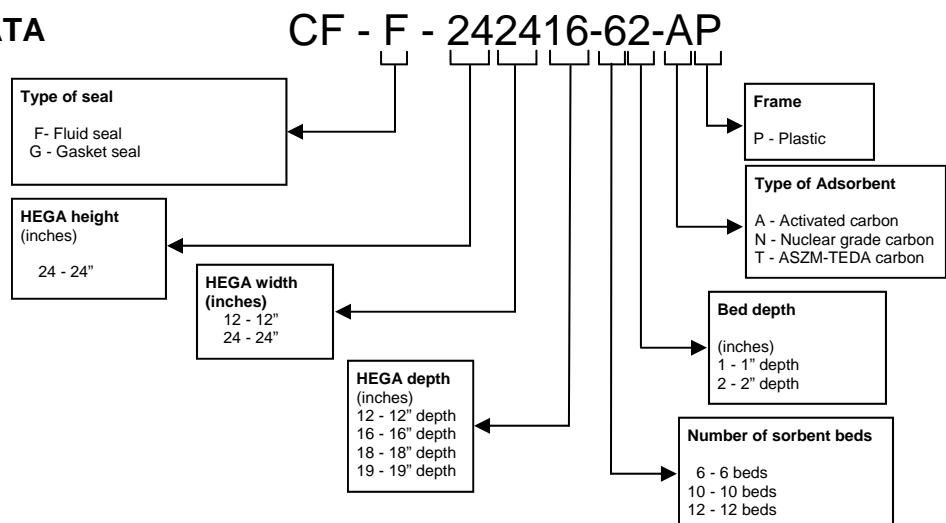

PERFORMANCE DATA

CAMFIL FARR HEGA FILTERS

Model Number	Media Type	Actual Size (inches)			Performance					
		Height	Width	Depth	Rated Airflow (cfm)	Residence Time (seconds)	Approximate Resistance* (inches w.g.)	No. of Beds	Bed Depth (inches)	Approximate Weight (pounds)
CF-F-241212-101-AP	A	24	12	12.25	500	0.083	1.00	10	1	44
CF-F-242412-101-AP			24	12.25	1000	0.083	1.00	10	1	83
CF-F-242416-62-AP			24	16.75	1000	0.143	1.35	6	2	115
CF-F-242416-121-AP			24	16.75	1250	0.115	0.75	12	1	133
CF-F-242418-62-AP			24	18.75	1250	0.129	1.70	6	2	128
CF-F-242419-121-AP			24	19.75	1500	0.115	0.95	12	1	150
CF-F-241212-101-NP	N	24	12	12.25	500	0.083	1.00	10	1	45
CF-F-242412-101-NP			24	12.25	1000	0.083	1.00	10	1	85
CF-F-242416-62-NP			24	16.75	1000	0.143	1.35	6	2	119
CF-F-242416-121-NP			24	16.75	1250	0.115	0.75	12	1	136
CF-F-242418-62-NP			24	18.75	1250	0.129	1.70	6	2	132
CF-F-242419-121-NP			24	19.75	1500	0.115	0.95	12	1	158
CF-F-241212-101-TP	T	24	12	12.25	500	0.083	2.00	10	1	50
CF-F-242412-101-TP			24	12.25	1000	0.083	2.00	10	1	94
CF-F-242416-62-TP			24	16.75	1000	0.143	3.10	6	2	134
CF-F-242416-121-TP			24	16.75	1250	0.115	1.40	12	1	150
CF-F-242418-62-TP			24	18.75	1250	0.129	3.70	6	2	143
CF-F-242419-121-TP			24	19.75	1500	0.115	1.65	12	1	171
CF-G-241212-101-AP	A	24	12	11.50	500	0.083	1.00	10	1	42
CF-G-242412-101-AP			24	11.50	1000	0.083	1.00	10	1	81
CF-G-242416-62-AP			24	16	1000	0.143	1.35	6	2	114
CF-G-242416-121-AP			24	16	1250	0.115	0.75	12	1	131
CF-G-242418-62-AP			24	18	1250	0.129	1.70	6	2	126
CF-G-242419-121-AP			24	19	1500	0.115	0.95	12	1	148
CF-G-241212-101-NP	N	24	12	11.50	500	0.083	1.00	10	1	43
CF-G-242412-101-NP			24	11.50	1000	0.083	1.00	10	1	83
CF-G-242416-62-NP			24	16	1000	0.143	1.35	6	2	117
CF-G-242416-121-NP			24	16	1250	0.115	0.75	12	1	134
CF-G-242418-62-NP			24	18	1250	0.129	1.70	6	2	130
CF-G-242419-121-NP			24	19	1500	0.115	0.95	12	1	156
CF-G-241212-101-TP	T	24	12	11.50	500	0.083	2.00	10	1	48
CF-G-242412-101-TP			24	11.50	1000	0.083	2.00	10	1	92
CF-G-242416-62-TP			24	16	1000	0.143	3.10	6	2	132
CF-G-242416-121-TP			24	16	1250	0.115	1.40	12	1	148
CF-G-242418-62-TP			24	18	1250	0.129	3.70	6	2	141
CF-G-242419-121-TP			24	19	1500	0.115	1.65	12	1	169

* Pressure drop may vary by ±20%.
 Published values are approximate resistance at rated airflow.

Specifications

CAMFIL FARR HEGA FILTERS

Camfil Farr HEGA Specification - Gasket Seal Models

Air Filters—1.0 General

1.1 - Air filters shall be high efficiency gas adsorbers, with (adsorbent selection), (number of beds) adsorbent beds, a (bed depth) bed depth enclosed in a high-impact polystyrene enclosing frame.

1.2 - Sizes shall be as noted on drawings or other supporting materials.

2.0 Construction

2.1 - Adsorbent shall be (activated virgin coconut shell carbon, nuclear grade carbon, ASZM-TEDA carbon).

2.2 - There shall be (number of beds) beds of adsorbent arranged in a v-bank configuration to reduce system resistance to airflow.

2.3 - Adsorbent bed depth shall be (1", 2"). Adsorbent screens shall be perforated and supported by external spacers to prevent bed distortion during filling and shake process.

2.4 - The enclosing frame shall be of high-impact polystyrene plastic and shall be designed for disposal through incineration. The frame shall form a rigid and durable enclosure.

2.5 - A 1/4" thick neoprene sealing gasket shall be included on the upstream side of the HEGA enclosing frame to form a positive seal upon installation.

3.0 Performance

3.1 - The HEGA shall have a minimum mechanical efficiency of 99.9%, and be tested and packaged in accordance with IEST-RP-CC-008-84.

3.2 - Resistance to airflow shall be approximately (Insert resistance)" w.g. at rated capacity.

3.3 - The HEGA filter shall be capable of operation to 120° F.

3.4 - The filter bed shall have a residence time of (insert value) seconds at (rated airflow) cfm.

3.5 - Manufacturer shall provide evidence of facility certification to ISO 9001:2000.

Filter shall be Camfil Farr model number (insert number).

Supporting Data - The HEGA shall be labeled as to tested efficiency, rated/tested cfm, pressure drop and shall be serialized for identification.

** Items in parentheses () require selection.*

Camfil Farr HEGA Specification - Fluid Seal Models

Air Filters—1.0 General

1.1 - Air filters shall be high efficiency gas adsorbers, with (adsorbent selection), (number of beds) adsorbent beds, a (bed depth) bed depth enclosed in a high-impact polystyrene enclosing frame.

1.2 - Sizes shall be as noted on drawings or other supporting materials.

2.0 Construction

2.1 - Adsorbent shall be (activated virgin coconut shell carbon, nuclear grade carbon, ASZM-TEDA carbon).

2.2 - There shall be (number of beds) beds of adsorbent arranged in a v-bank configuration to reduce system resistance to airflow.

2.3 - Adsorbent bed depth shall be (1", 2"). Adsorbent screens shall be perforated and supported by external spacers to prevent bed distortion during filling and shake process.

2.4 - The enclosing frame shall be of high-impact polystyrene plastic and shall be designed for disposal through incineration. The frame shall form a rigid and durable enclosure.

2.5 - The HEGA shall include a 3/4" channel, filled with urethane gel on the upstream side of the HEGA to form a positive seal upon installation. The HEGA shall include (4) four filter clips on the side opposite the gel channel.

3.0 Performance

3.1 - The HEGA shall have a minimum mechanical efficiency of 99.9%, and be tested and packaged in accordance with IEST-RP-CC-008-84.

3.2 - Resistance to airflow shall be approximately (Insert resistance)" w.g. at rated capacity.

3.3 - The HEGA filter shall be capable of operation to 120° F.

3.4 - The HEGA bed shall have a residence time of (insert value) seconds at (rated airflow) cfm.

3.5 - Manufacturer shall provide evidence of facility certification to ISO 9001:2000.

Filter shall be Camfil Farr model number (insert number).

Supporting Data - The HEGA shall be labeled as to tested efficiency, rated/tested cfm, pressure drop and shall be serialized for identification.

** Items in parentheses () require selection.*

Camfil Farr, Inc.

Washington NC Tel: (252) 975-1141 Fax: (252) 975-1041

Corporate Locations:

United States Tel: (973) 616-7300 Fax: (973) 616-7771

Canada Tel: (450) 629-3030 Fax: (450) 662-6035

E-mail: camfilfarr@camfilfarr.com

© Camfil Farr

<http://www.camfilfarr.info>

<http://www.camfilfarr.com>

Camfil Farr has a policy of uninterrupted research, development and product improvement. We reserve the right to change designs and specifications without notice.

