

filtra 2000™ Gel

High-Capacity Gel-Seal V-Style Absolute Filter with Airflow Capability to 2294 CFM

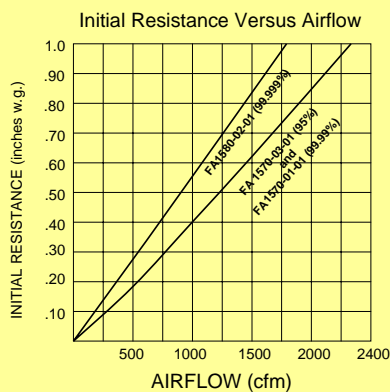

Critical airflow and energy savings are optimized, operating at airflow capacities of up to 2294 cfm.



The above graph represents 24" by 24" by 12" models with maximum media area. Please consult the chart on the rear of this page for additional options.



The Camfil Farr Filtra 2000™ provides high-efficiency particulate air filtration for critical application processes. With more than double the media of standard HEPA filters, critical airflow and energy savings are always optimized. Available in airflow capacities up to 2294 cfm the Filtra 2000 includes:

- Wet-laid water-resistant micro fiber glass media capable of withstanding up to 99% relative humidity
- Multiple high-efficiency media packs in a V-bank design optimized for low configuration loss and optimum airflow
- Low initial resistance to airflow of 1.0" w.g. at rated capacity
- CMST™ - Exclusive *controlled media spacing*™, a Camfil Farr manufacturing method that ensures uniform airflow throughout the entire media pack
- Up to 401 square feet of media, resulting in lower average pressure drop, longer periods between changes and lower disposal costs. The Filtra 2000 may offer 3-4 times the life of a standard absolute filter
- A gel-seal channel filled with a unique elastic gel sealant to ensure a leak free interface between filter mounting hardware and filter
- Installs in any standard knife-edge HEPA mounting system without modifications (may require alternate fasteners)
- Each unit is individually tested and certified (serialized on the product label) noting actual tested performance values.

The Camfil Farr Filtra 2000 applications include medical facilities, pharmaceuticals, semiconductor facilities, food processing plants and other locations where ultra clean air and critical filter performance is required.

Increasing filter surface area by 50% can increase filter life by 100%. A filter with twice the surface area can last 3 to 4 times as long.

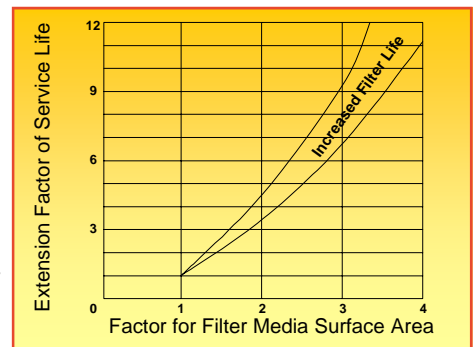

Camfil Farr	Product sheet
Filtra 2000™ Gel	1823Gel - 0606
Camfil Farr—clean air solutions	

PERFORMANCE DATA

FILTRA 2000™ Gel

Model	Efficiency	Nominal Size H x W x D (inches)	Airflow (cfm)	Resistance @ Airflow (inches w.g.)	Media Area (sq. ft.)	Shipping Weight (lbs.)
FA1575-03-01	95% @ 0.3 Micron	24 x 12 x 11.50	864	0.50	162	22
FA1573-03-01		24 x 24 x 11.50	1437		221	26
FA1571-03-01		24 x 24 x 11.50	1908		363	35
FA1570-03-01		24 x 24 x 11.50	2294		401	40
FA1575-01-01	99.99% @ 0.3 Micron	24 x 12 x 11.50	864	1.0	162	22
FA1573-01-01		24 x 24 x 11.50	1437		221	26
FA1571-01-01		24 x 24 x 11.50	1908		363	35
FA1570-01-01		24 x 24 x 11.50	2294		401	40
FA1575-02-01	99.999% @ 0.3 Micron	24 x 12 x 11.50	665	1.0	162	22
FA1573-02-01		24 x 24 x 11.50	1106		221	26
FA1571-02-01		24 x 24 x 11.50	1469		363	35
FA1580-02-01		24 x 24 x 11.50	1766		401	40

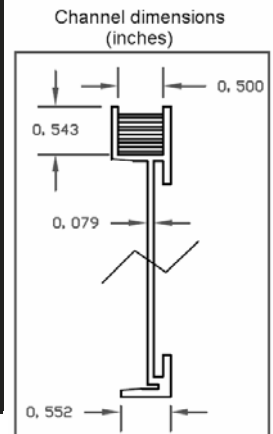

The detail above notes channel dimensions for Filtra 2000 gel seal filters.

For special application Filtra 2000 gel seal filters for Camfil Farr S & P Housings consult Product Sheet 1823GS.

DATA NOTES:

For Filtra 2000 Gel units specific to Camfil Farr S & P Housings see Product Sheet 1823GelCDimensions are actual. Consult Camfil Farr Sales submittal drawings for additional product detail.

Maximum operating temperature 175° F (80° C).

All materials are fire-retardant and self-extinguishing The Filtra 2000 is qualified as UL 586 and UL 900 Class 2.

IEST—Institute of Environmental Sciences & Technology. CEN conversions are available on the Camfil Farr web site.

Additional sizes are available. Consult factory for availability and pricing.

Filtra 2000 filters are also available with seamless, and dove-tail gaskets.

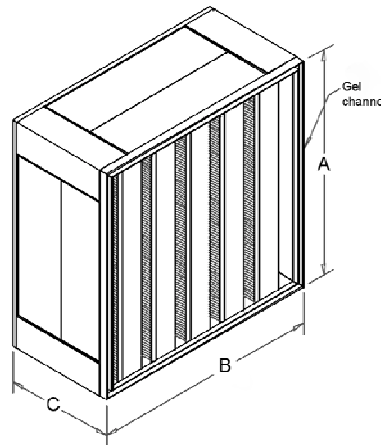

SPECIFICATIONS

1.0 General

1.1 - Air filters shall be absolute grade HEPA filters consisting of pleated media packs assembled in a V-bank configuration, polyurethane sealant, anodized aluminum enclosure and seamless sealing gasket.

1.2 - Sizes shall be as noted on enclosed drawings or other supporting materials.

2.0 Construction

2.1 - Filter media shall be micro fiber glass formed into minipleat pleat-in-pleat V-bank design.

2.2 - The media packs shall be potted into the enclosing frame with fire retardant polyurethane sealant.

2.3 - An enclosing frame of anodized extruded aluminum shall form a rugged and durable enclosure.

2.4 - The filter shall include a sealing channel 0.50" wide by 0.543" deep filled with an elastic gel to create a positive seal between filter and filter mounting hardware.

3.0 Performance

3.1 - Filter efficiency at 0.3 micron shall be (95%, 99.99%, 99.999%)* when evaluated according to the IEST Recommended Practice for applicable type. Each filter shall be labeled as to tested performance.

3.2 - Initial resistance shall be 1.0" w.g. target at rated airflow. (0.50" w.g. for 95%)*.

3.3 - Filter shall be qualified as UL 586 and UL 900 Class 2 per Underwriters Laboratories.

3.4 - Manufacturer shall provide evidence of facility certification to ISO 9001:2000.

* Items in parentheses () require selection.

Camfil Farr has a policy of uninterrupted research, development and product improvement. We reserve the right to change designs and specifications without notice.

Camfil Farr, Inc.

United States Tel: (973) 616-7300 Fax: (973) 616-7771

Canada Tel: (450) 629-3030 Fax: (450) 662-6035

E-mail: camfilfarr@camfilfarr.com

© Camfil Farr

<http://www.camfilfarr.info>
<http://www.camfilfarr.com>

