



ASME AG-1 Absolute®

ASME AG-1 Size 4, 5 and Size 7 HEPA Filters



Camfil Farr nuclear-qualified AG-1 Absolute HEPA filters are manufactured per the ASME AG-1¹ Code and are UL-586² listed. They are manufactured from the highest quality components as prescribed in Section FC, Article 3000 of the ASME AG-1 code. Each design has been qualified per the requirements of Section FC, Article 5000. Every filter is manufactured under an audited and approved ASME NQA-1 Quality Program. Camfil Farr provides a Certificate of Conformance as specified in Article FC-8000 of ASME AG-1.

Each nuclear grade AG-1 Absolute filter has a tested efficiency of not less than 99.97% on 0.2-0.3 micron size particles at 100% of rated airflow and at 20% of rated airflow. The label attached to each filter furnishes individual filter test results.

Every Camfil Farr nuclear grade AG-1 Absolute filter:

- Includes media qualified per ASME AG-1, Appendix FC-I.
- Is highly resistant to moisture and capable of operation to 99% relative humidity.
- Uses a fire-retardant phosphorus-free polyurethane adhesive sealant bonding the frame to the media pack.
- Has a 14-gauge ASTM³ A-240 Type 304 stainless steel enclosing frame.
- Includes 4 x 4 wire mesh fabric face guards on the air-entering and air-exiting sides of each media pack.
- All Sizes are available in gasket seal (in accordance with ASME AG-1, FC-3121) and gel seal versions (in accordance with ASME AG-1, FC-3122) to ensure a leak-free filter to housing or filter to frame seal.
- Gel seal models may include optional filter extraction clips to accommodate filter change in bag-in/bag-out containment systems.
- May be operated at continuous temperature of up to 250° F (121° C) .
- Is labeled as specified in ASME AG-1, FC-9000 and in DOE⁴ STD-3020-2005, 6.1.4.
- Includes special crating as described by DOE STD-3020-2005. These shipping crates are fabricated from wood components. The removable top lid and front are secured with removable fasteners for ease of removal and repackaging.

Absolute filter integrity in compliance with ASME AG-1

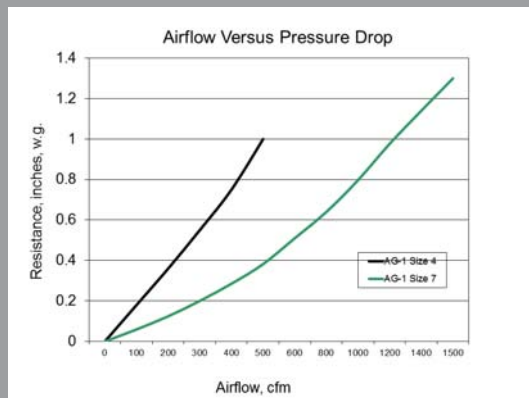

The Camfil Farr AG-1 Absolute's integrity ensures continued protection of hazardous environments, and when changed in accordance with recognized procedures, protects the health of filter service personnel.

¹ ASME - American Society of Mechanical Engineers

² UL - Underwriters Laboratories

³ ASTM - American Society for Testing and Materials

⁴ DOE - Department of Energy

Performance

ASME AG-1 Size Designation	Seal (Type/Location) (See Note 3 below)	Nominal Filter Size Height (H) x Width (W) x Depth (D) (inches)	Airflow Capacity (cfm)	Maximum Initial Resistance @ Capacity (inches w.g.)	Effective Media Area (square feet)	Part Number
7	Gel/Upstream	24 x 24 x 11-1/2	1500	1.3	303	855211527
	Gel/Downstream					855211138
	Gasket/Upstream					855210872
	Gasket/Downstream					855211139
5	Gel/Upstream	24 x 24 x 11-1/2	1000	1.0	212	Contact Factory
	Gel/Downstream					Contact Factory
	Gasket/Upstream					855211383
	Gasket/Downstream					855211310
4	Gel/Downstream	24 x 24 x 5-7/8	500	1.0	108	855211141
	Gasket/Downstream					855211140

DATA NOTES

1. Rated airflow in ACFM based on tests indoors at atmospheric pressure.
2. Gasket seal dimensionals shown to the right, gel seal version not shown.
3. All gel seal filters listed in the above table have extraction clips included.
4. Minimum efficiency is 99.97% on particles 0.2-0.3 micron in size.
5. Maximum continuous operating temperature 250° F (121° C).
6. Final operating resistance should not exceed 4.0" w.g.
7. ASME AG-1 Absolute filters meet all applicable requirements as published under in the following documents; ASME AG-1, NQA-1, N509, and UL 586.
8. Camfil Farr nuclear grade HEPA filters have been qualified by the Edgewood Chemical Biological Center to meet the performance requirements of ASME AG-1 Sections FC-4000 and FC-5000, with the exceptions of FC-5150 (Resistance to Heated Air) and FC-5160 (Spot Flame Resistance) which have been qualified by the UL 586 listing of the product.
9. For complete construction components please factory representative for sales submittal drawings.

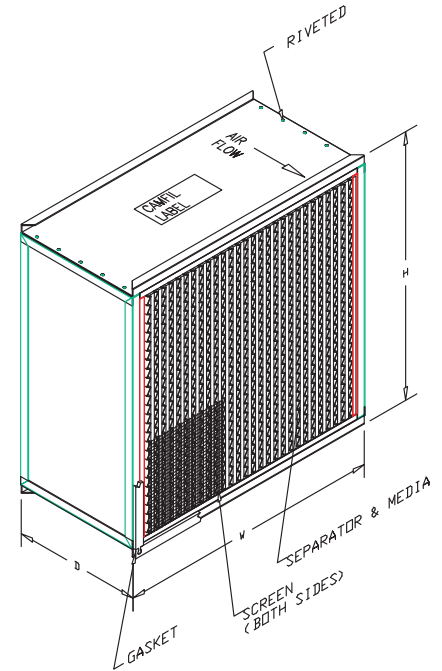

Camfil Farr AG-1 Air Filter Specification

1.0 General

1.1 - Air filters shall be Camfil Farr Model _____ ASME AG-1 qualified and UL 586 listed HEPA air filters with ASME AG-1, Appendix FC-I qualified HEPA media in the ASME AG-1, FC-1121 Type A pleat configuration, polyurethane media-to-frame sealant, Type 304 stainless steel enclosing frame, 18 gauge 4x4 wire mesh media pack face guards and a filter face seal to ensure filter seal integrity.

1.2 - Overall dimensions shall be 24" high by 24" wide by 11-1/2 deep for Sizes 5 and 7 filters and 24" high by 24" wide by 5-7/8" deep for Size 4 filters.

2.0 Construction

2.1 - The media shall be manufactured from waterproof borosilicate glass micro fibers and a synthetic binder formed into a continuous flat sheet with physical and functional properties. The test results shall be traceable to manufacturing lot number, roll number and the serial number of the final product. The media shall be qualified in accordance with ASME AG-1, Appendix FC-I.

2.2 - The media pack shall be potted into the enclosing frame through the use of a polyurethane sealant.

2.3 - The enclosing frame shall be of 14-gauge Type 304 stainless steel and bonded to the media pack to form a rugged and durable enclosure. Overall dimensional tolerance shall be +0/- 1/8" on the face dimensions, +1/16" / - 0 on the depth dimension. The face shall be square within a tolerance of 1/8" when measured diagonally across the corners of both faces.

2.4 - The assembled filter shall include media pack faceguards constructed of 4x4 mesh wire fabric made from 18 gauge galvanized steel wire. The faceguards shall be on the air-entering and air-exiting sides of the media pack. The faceguards shall have a minimum open area of 69%.

2.5 - For Gasket seal applications, a 1/4 x 3/4 neoprene gasket, in accordance ASME AG-1 FC-3121, will be applied to the upstream or downstream face flange. For Gelatinous seal applications, the filter shall include a continuous channel located upstream or downstream and filled with silicone gel in accordance with ASME AG-1, FC-3122. Four filter extraction clips shall be provided, (if specified), for filters installed in a bag-in/bag-out containment housing.

3.0 Performance

3.1 - The filter shall be qualified to meet the performance requirements of ASME AG-1, Sections FC, Article 4000 and FC, Article 5000.

3.2 - The filter shall be listed by Underwriters Laboratories as UL 586 and labeled accordingly.

3.3 - The filter shall be capable of operating at 250° F (121° C) continuous.

3.4 - Manufacturer shall supply a Certificate of Conformance with each filter detailing manufacturers name, model number, unique filter serial number, resistance to airflow at rated capacity, percent penetration on particles 0.3 micron in size at 100% of rated airflow and at 20% of rated airflow. The filter shall be labeled as specified in ASME AG-1, FC-9000 and in DOE STD-3020-2005, 6.1.4.

3.5 - Finished filters are securely packaged and are crated. Crating shall be constructed as described by DOE STD-3020-2005. These shipping crates shall be fabricated from wood components. The removable top lid and front shall be secured with removable fasteners for ease of removal and repackaging.

¹ Gelatinous seal of Polydimethylsiloxane.